

LOGSTOR TMC-C Installation Instructions - Industry



TMC-C

T-joint, open

Installation instructions

1/4

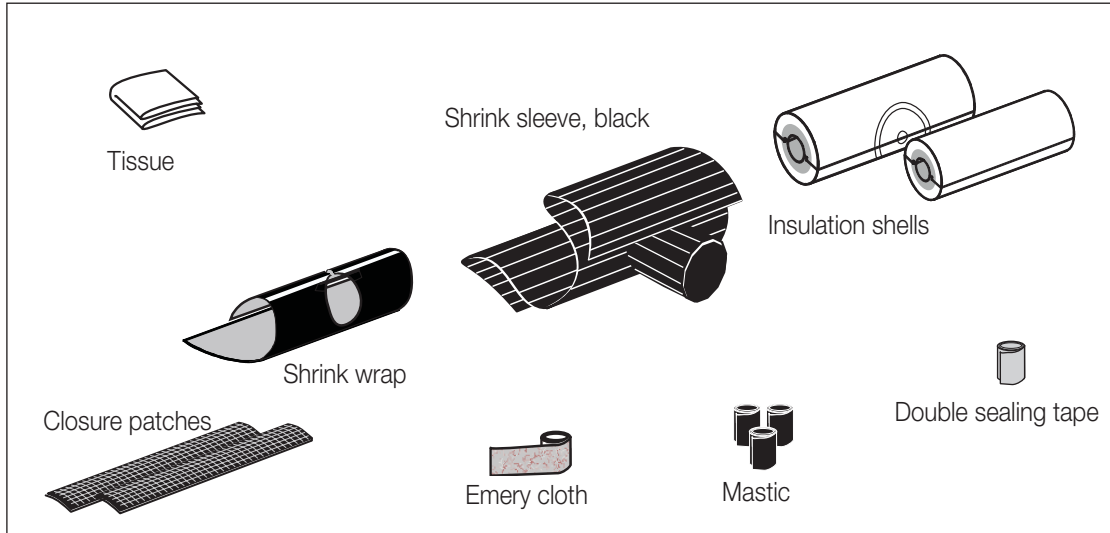

Important:

Never apply heat to creases, if any, since the sleeve material will be discoloured and the surface will crack.

Never apply heat underneath the sleeve at the ends, since this may damage the sleeve permanently.

Pockets of air under the sleeve can be removed by bending a piece of welding wire into U-shape and pushing it underneath the sleeve while it is still warm.

Use burner head $\varnothing 51$ mm for sleeves up to $\varnothing 200$ mm. For larger sleeves use burner head $\varnothing 63$ mm.

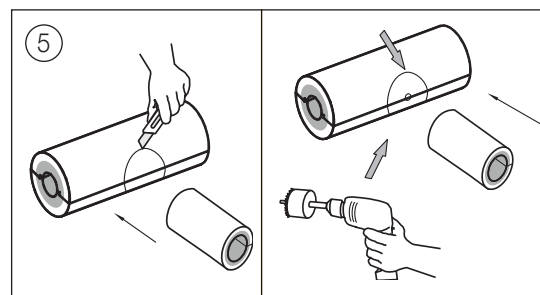
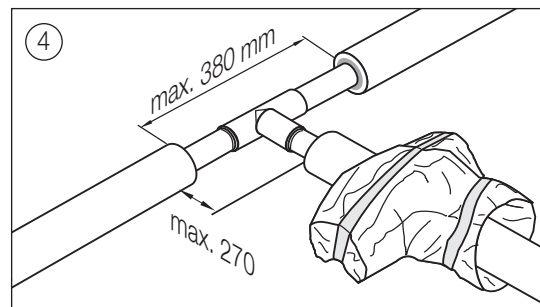
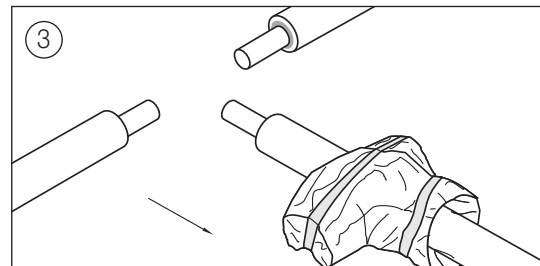
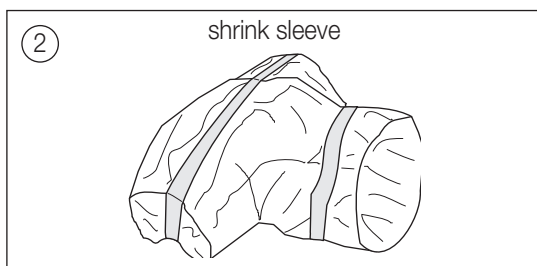
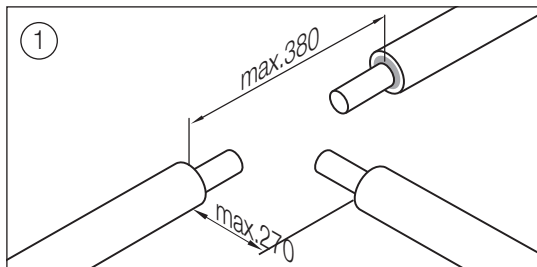

TMC-C

T-joint, open

Installation instructions

2/4

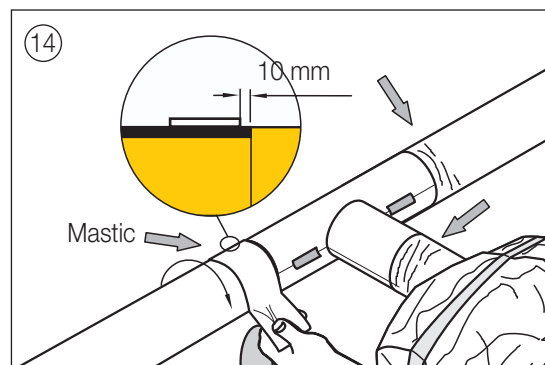
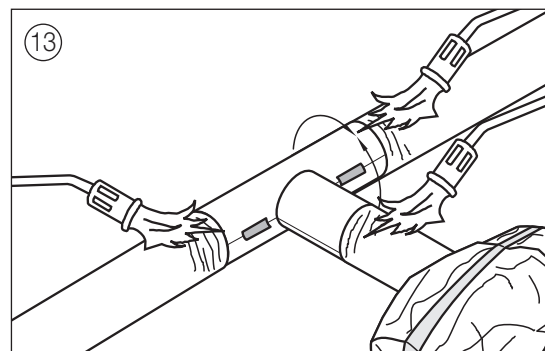
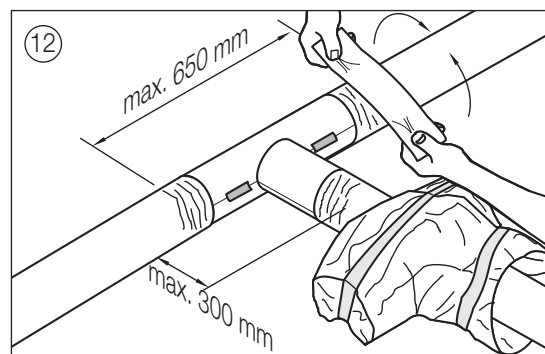
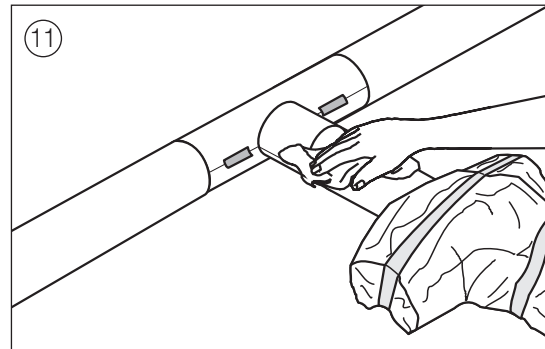
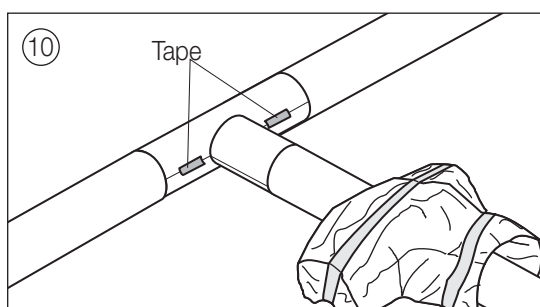
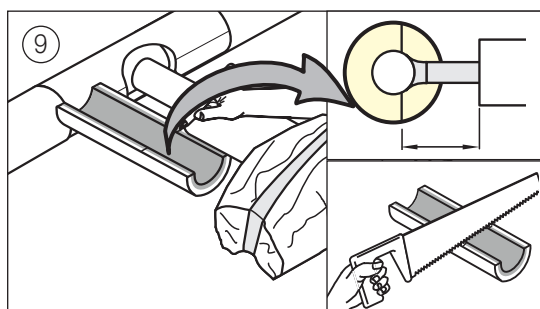
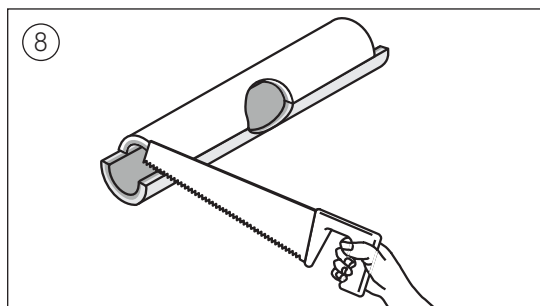
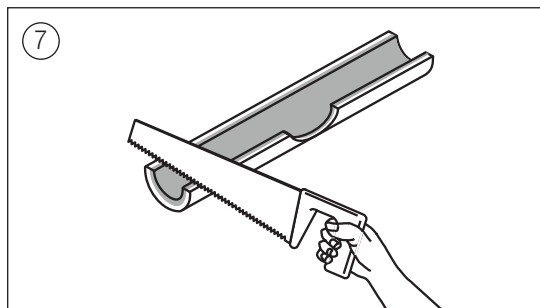
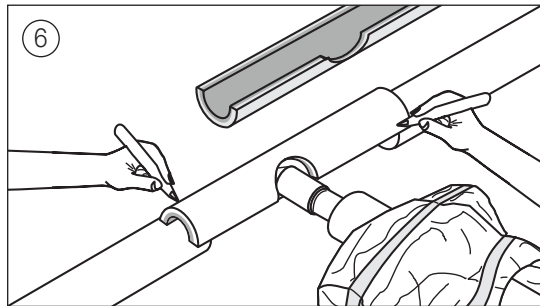

TMC-C

T-joint, open

Installation instructions

3/4

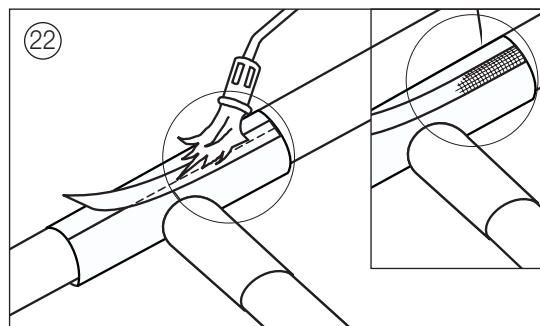
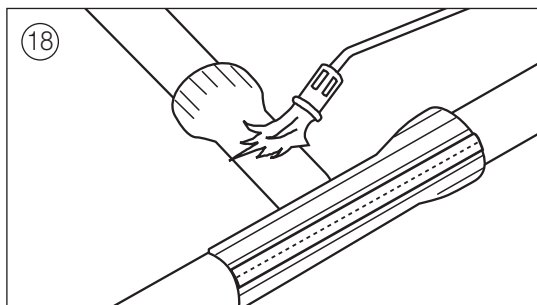
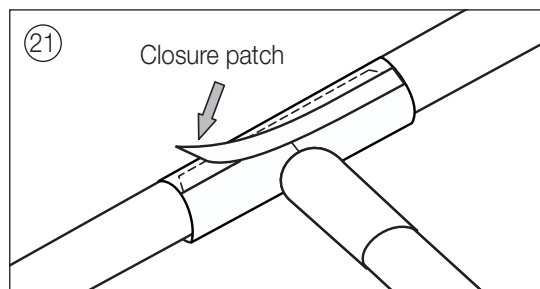
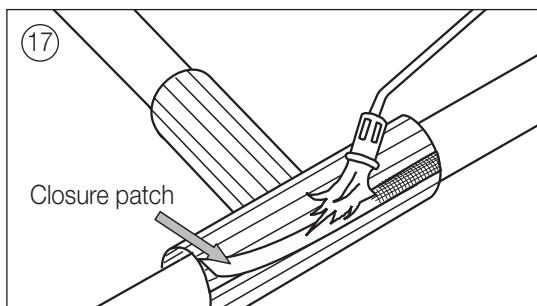
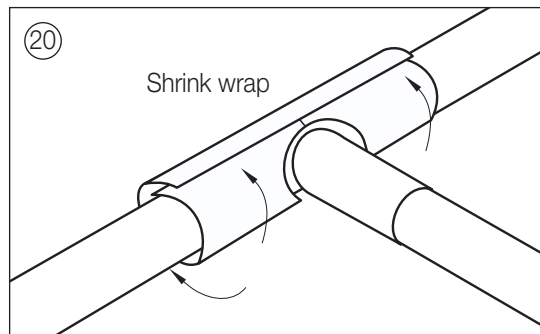
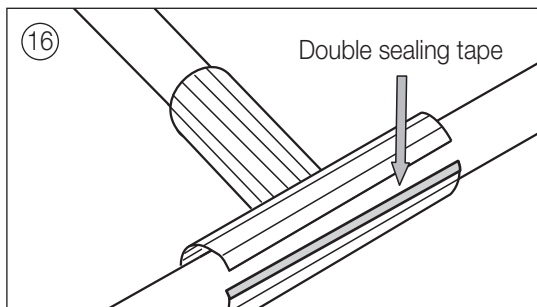
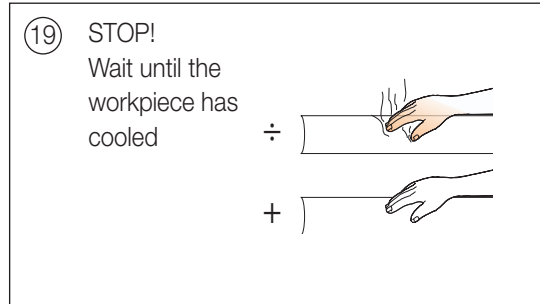
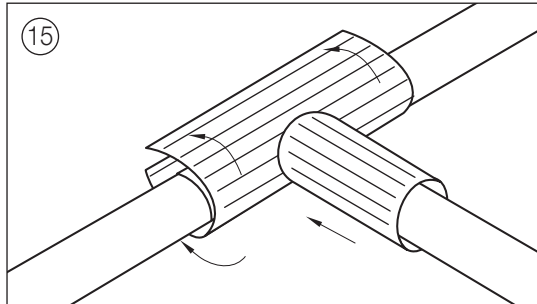

TMC-C

T-joint, open

Installation instructions

4/4

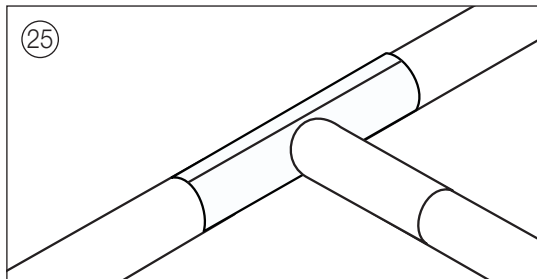
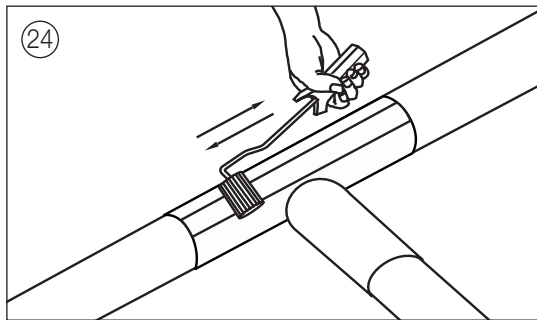
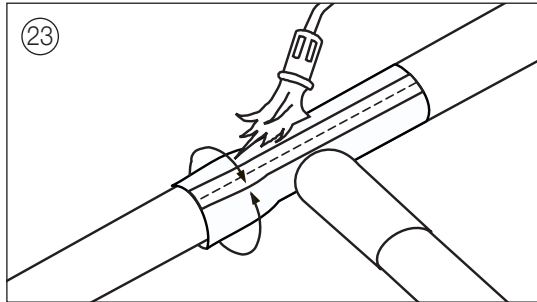

Contact details

Denmark

LOGSTOR Denmark Holding ApS
Danmarksvej 11 | DK-9670 Løgstør

T: +45 99 66 10 00
E: logstor@kingspan.com



For the product offering in other markets please contact your local sales representative or visit www.logstor.com

Care has been taken to ensure that the contents of this publication are accurate, but Kingspan Limited and its subsidiary companies do not accept responsibility for errors or for information that is found to be misleading. Suggestions for, or description of, the end use or application of products or methods of working are for information only and Kingspan Limited and its subsidiaries accept no liability in respect thereof.

To ensure you are viewing the most recent and accurate product information, please scan the QR code directly above.

